

6

5

4

3

2

1

D

D

C

C

B

B

A

A

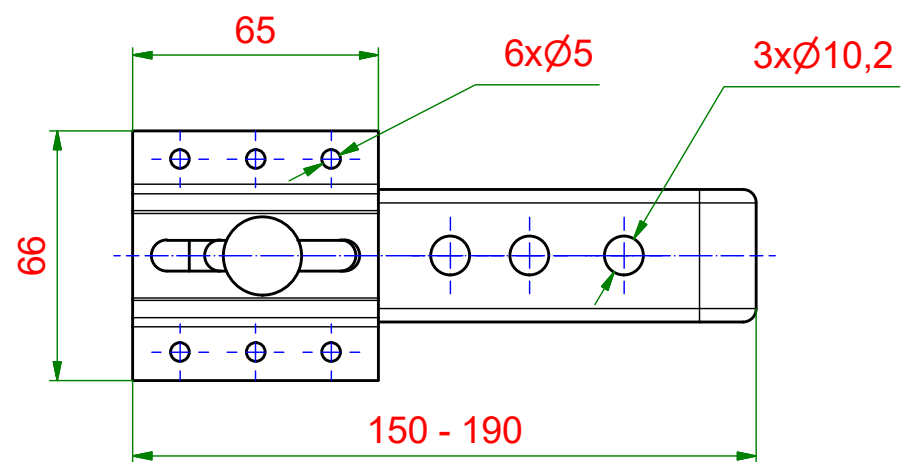
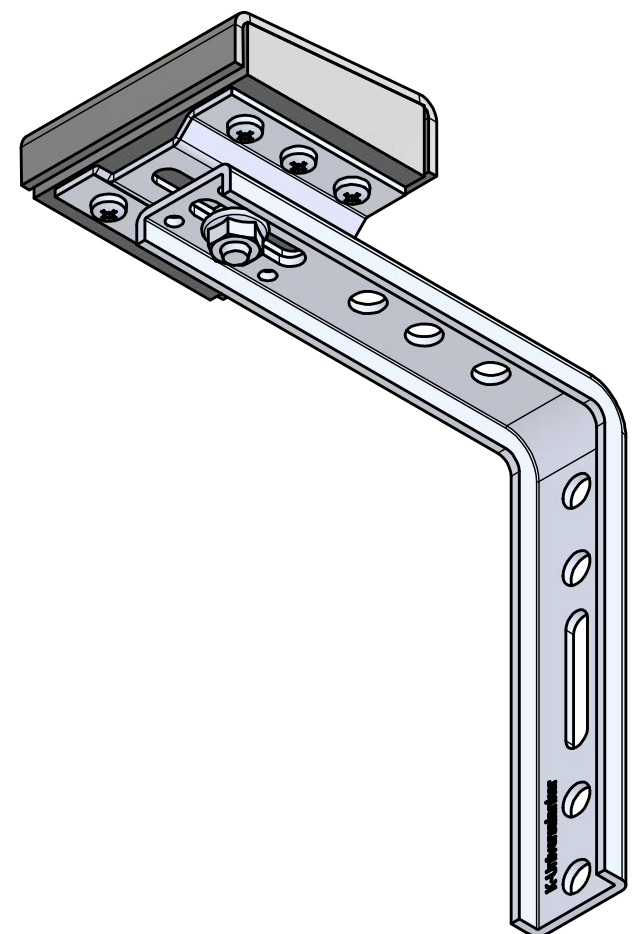
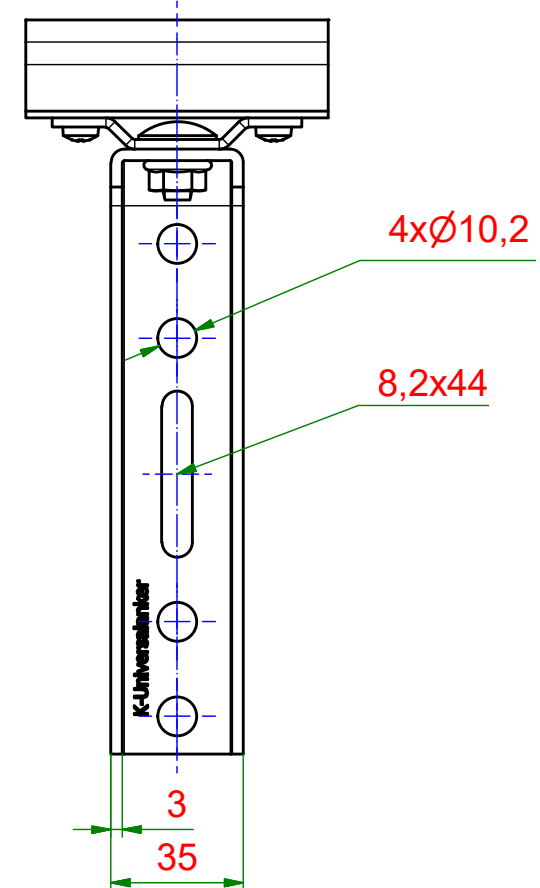
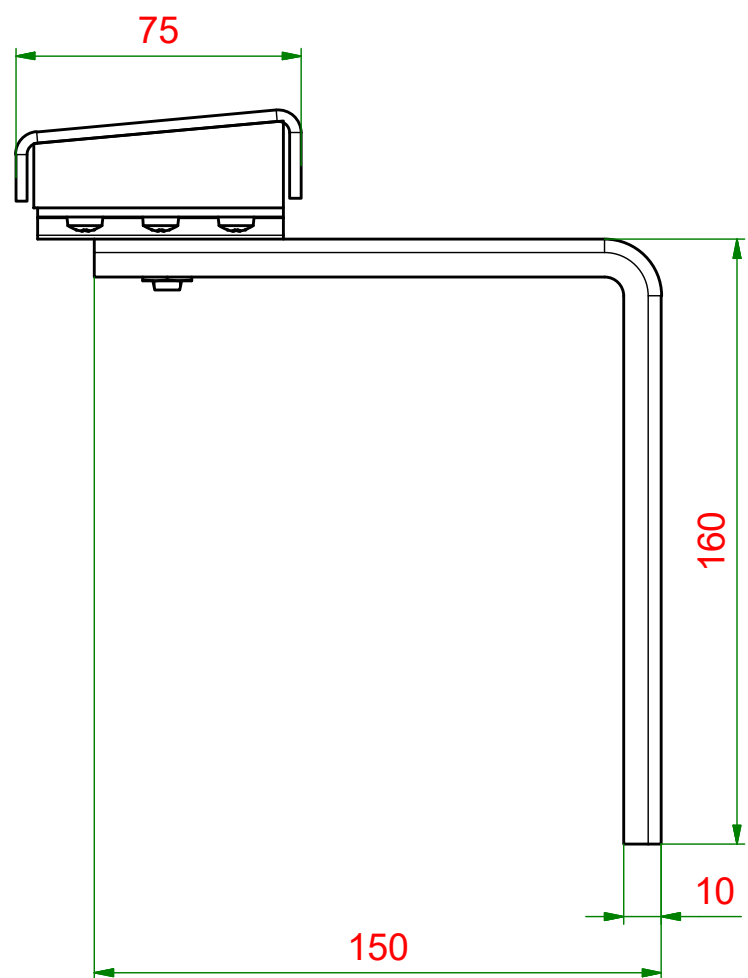

KNELSEN Entwicklung und Herstellung Knelsen GmbH Am Schlinge 26 33154 Salzkotten Tel.: 05258 / 93766-95 Fax: 05258 / 93766-97 www.knelsen.de info@knelsen.de		Material: verzinkter Stahl		
		Maßstab: 1 : 2	Masse: 0,7 kg	
	Datum Name	Titel, Beschreibung T-SFBH 160-200 Thermo-Steifensterbankhalter		
	Erstellt Genehmigt	02.07.2020 R.Heiermeier	Bauteilnummer / Zeichnungsnummer 405162	
Allgemeintoleranzen nach ISO 2768-m		Blatt 1		
Schutzvermerk nach DIN ISO 16016 beachten		A3		

6

5

4

3

2

1